

# Rail Brake HR 185 FHM

spring activated – hydraulically released



Features	Code
Brake	H
Rail	R
Frame size 185	185
Spring activated	F
Hydraulically released	H
Manual adjustment to accommodate friction block wear	M
Max. clamping force 530 kN	530

### Example for ordering

Rail Brake HR 185 FHM,  
max. clamping force 530 kN:

HR 185 FHM-530

### Technical Data

Braking force	300 kN
Clamping force on the rail	530 kN
Nominal pad gap (total)	10 mm
Oil pressure	min. 230 bar max. 250 bar
Oil volume	max. 450 cm <sup>3</sup>
Weight	430 kg

# Rail Brake HR 185 FHM

RINGSPANN®

spring activated – hydraulically released

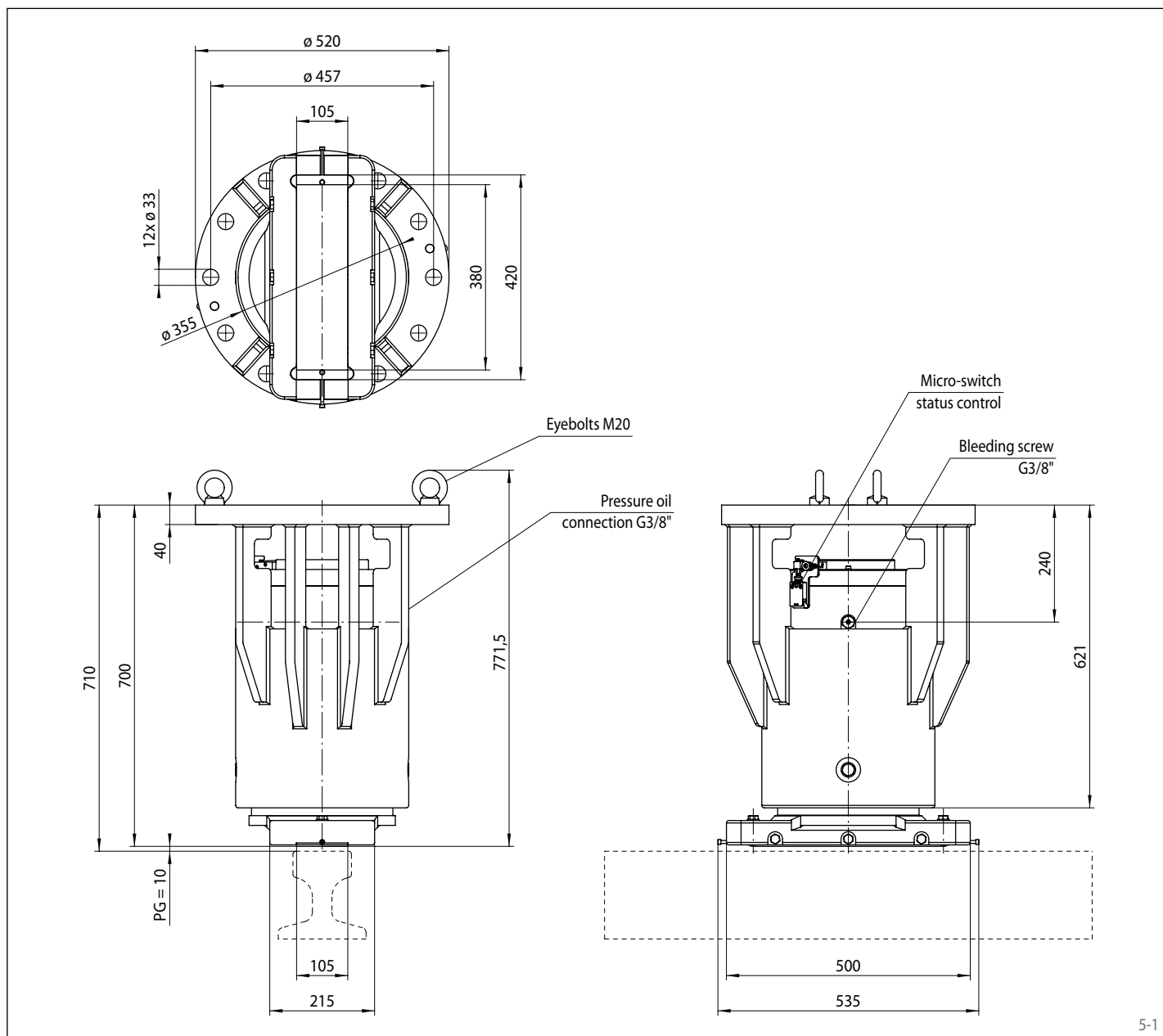

## Working conditions

- Ambient temperature: -20 °C / +60 °C
- Air humidity: <90%

## Monitoring switch

- 240 VAC 1.5 A; 250 VDC 0.1 A
- Cable 5 x 0.75 mm<sup>2</sup>, length 2 m, outer diameter 7.5 mm
- Protection type IP67

## Options

- Assembly set (screw and washers)
- Stainless steel cover
- Seawater execution

## Notes

- Fastening:
  - 12 screws M 30 class 8.8 (optional)
  - Cs: 1 350 Nm +/- 5%;  $\mu=0,15$